

USER MANUAL : SAFE-T-PROOF รุ่น WR-2-01 EV/SAFE

Safe-T-Cut Smart Model DGL2-63B is an automatic earth leakage circuit breaker type RCDs/RCCB designed to be used.

Only an additional connection point from the existing electrical system that already has a circuit breaker to protect against overcurrent. Suitable for applications such as EV charging systems, medical electrical systems, elevators, solar PV systems, etc. to protect people from electric shock (electric shock).

- It is a protective device for earth leakage current. that can cut off the leakage current to the ground, both alternating current (AC) and direct current (DC) leakage to the ground
- Designed for use with EV charging systems or other battery powered devices such as inverters, uninterruptible power supplies (UPSs), and other circuits that require DC leakage protection.
- Confidence in quality. Passed international standards IEC 61008-1, EN 62423

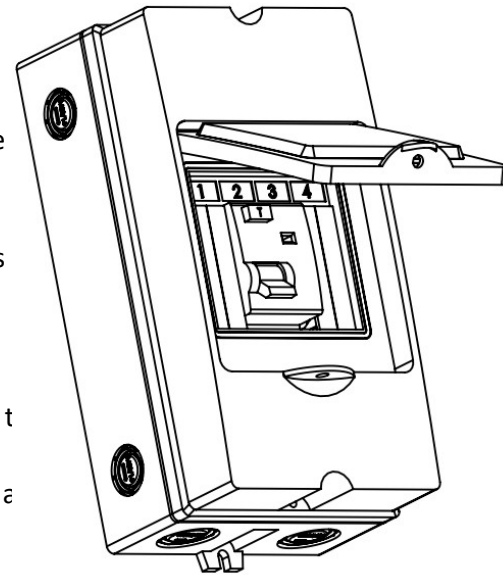

Application

1. After installing the RCCB, push the switch lever (1) up to the “ON” position. The RCCB will supply current to the load immediately.
2. Then try to press the TEST button (2), the RCCB will cut off the circuit immediately. indicates that the normal machine is ready to use. Notice that the indicator box (3) will turn red.
3. While in use, when there is an abnormality from electric shock (leakage through people), the RCCB will cut off the circuit immediately in less than 0.1 seconds and once the fault has been fixed, move the switch (1) to the “ON” position, the RCCB is ready to continue working.
4. You can test the operation of the RCCB by yourself by pressing the TEST button (2). Normally, the circuit must be cut every time. Before pushing the switch (1), “ON” should be turned off all switches/electrical usage. In particular, unplug the electric vehicle charger and all peripheral electrical equipment. To prolong the service life of electrical appliances, if the TEST button is pressed, the RCCB does not cut off, please contact an experienced electrician to check immediately. Or contact the Safe-T-Cut Smart service center for advice.
5. It is recommended to press the TEST button (2) every time before use.

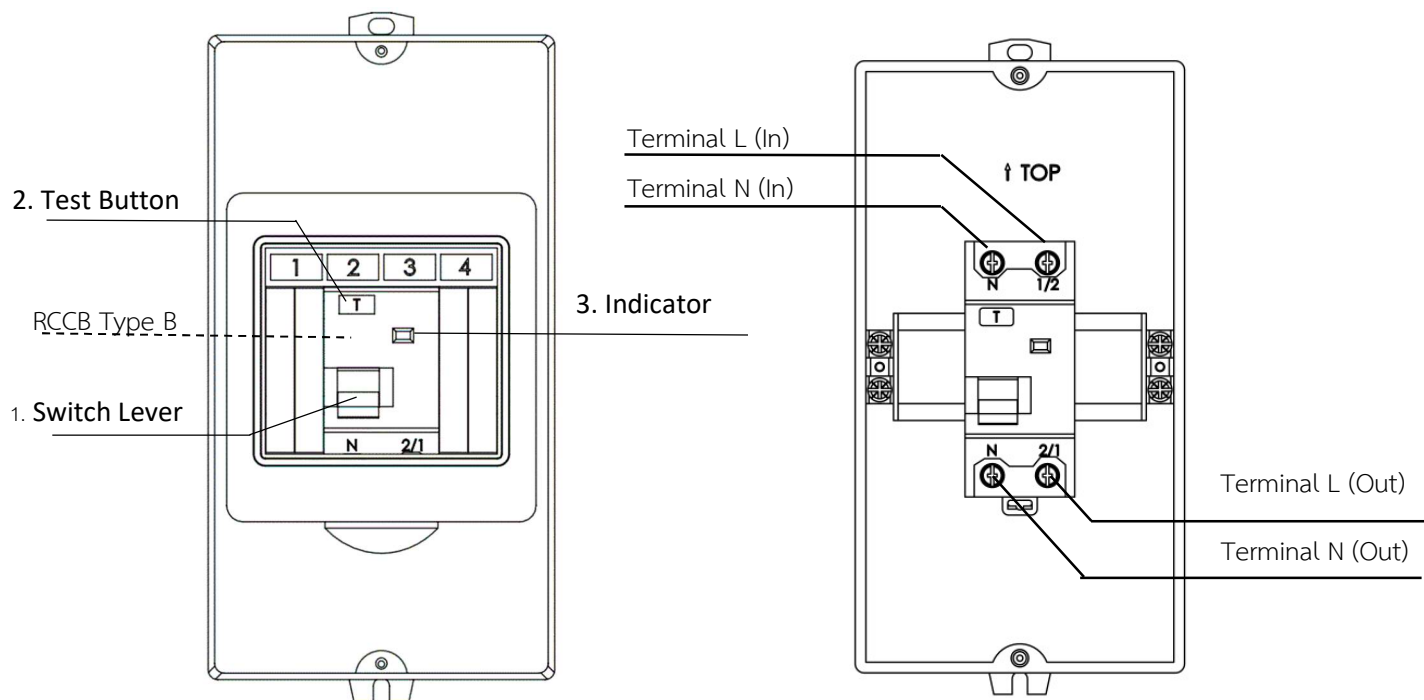

## Specification

Model	WR-2-01 EV/SAFE
Rated Voltage (Un)	230 V
Number of Pole	4 Pole
Ingress Protection	IP 65
Dimension	11 x 20 x 9
<b>RCCB (DGL2-63B)</b>	
Pole	2 Pole (1P+N)
Rated Current (In)	40A
Rated Voltage (Un)	230VAC
Rated Frequency	50 Hz
Rated Residual Operating Current (I $\Delta$ n)	30mA
RCCB (Break time of a RCCB)	$\leq 0.1$ sec
Rated conditional short-circuit current (Inc)	10000A
Rated Making and Breaking Capacity (I $\Delta$ m)	1000A
Ingress Protection	IP20
Wave form of the earth leak current sensed (Type)	AC, A, F, B
Operating Temperature	-25~+45, max. 95 % humidity
Terminal tightening torque	3.5N.m
Standard	IEC/EN 61008-1, 62423
Total Weight (Included RCCB & Box)	0.67 kg

Dimension

